

Specifications:
 Material And Finish:
 Insulator:Nylon 6T UL94V-0 Color:Natural
 Pin Material:Brass
 Solder Tabs:Brass
 Plated:See Ordering Information

Rating:
 Current Rating:1.0 Amp
 Voltage Rating:150V AC/DC
 Operating Temperature Range:-25~+85°C

Electrical:
 Contact resistance:30m Ohm Max
 Insulator resistance:500M ohm min.
 Withstanding Voltage:500V AC/Minute

Ordering Information

A12522M-XXX-02-X
 1 2 3 4 5

- 1: — Series No.
- 2: — M:SMT Type
- 3: — No. of Positions
- 4: — A:Gold Flash
S:Matte Tin
- 5: — A:In bag
B:In Tube
C:In Tray
D:In Tape&Reel

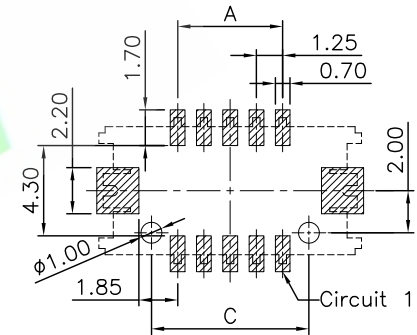
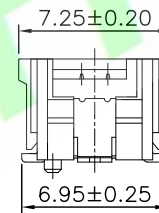
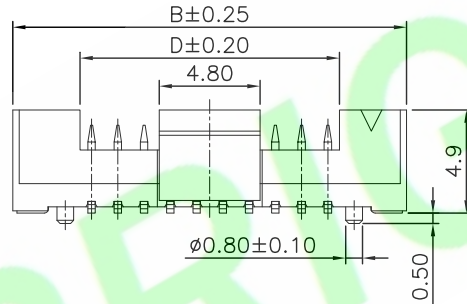
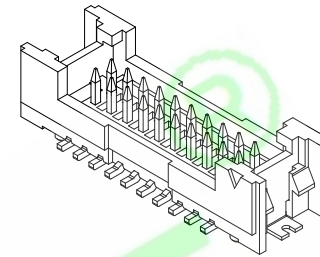
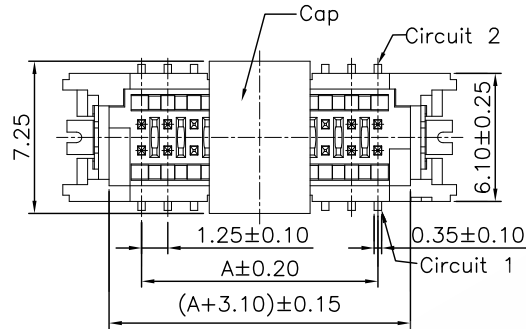

Recommended PCB Layout
 Tolerance:±0.05mm

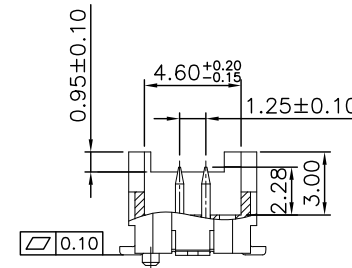
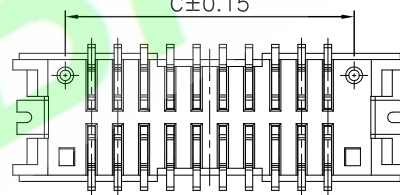

Circuit No.	Dimensions			
	A	B	C	D
10	5.00	12.50	7.50	6.10
12	6.25	13.75	8.75	7.35
14	7.50	15.00	10.00	8.60
20	11.25	18.75	13.75	12.35
30	17.50	25.00	20.00	18.60
34	20.00	27.50	22.50	21.10
36	21.25	28.75	23.75	22.35
40	23.75	31.25	26.25	24.85
42	25.00	32.50	27.50	26.10

5X				DR.BY.: Samson
4X				CHKD.: Tony
3X				APPD.: Billy
2X	ORIGINAL	Samson		
1X	DESCRIPTION	DR.BY	ECN. NO.	
REV.				

GENERAL TOLERANCE:	
LINEAR	ANGLES
X.: ±0.30	X': ±5.0°
X.X: ±0.25	X.X': ±3.0°
X.XX: ±0.15	X.XX': ±2.0°
X.XXX: ±0.10	X.XXX': ±1.0°

PART NO : A12522M-XXX-02-X
DWG. NO.:
TITLE : 1.25mm Pitch 180° DUAL ROW Wafer SMT Type(With boss)
DATE: 10-Oct-2017

HJBRIGHT 东莞市華晶電子有限公司
 BRIGHT-E ELECTRONIC TECHNOLOGY LIMITED

SHEET: 1/1
 SCALE: 1:1
 UNIT: mm

THIRD ANGLE PROJECTION

A4