

Specifications:

Material And Finish:

Insulator:PA6T(HTNFR52G30NH BK337) UL94V-0
 Color:Black
 Contact:Phosphor Bronze(C5210R-H)
 Plated:See Ordering Information

Rating:

Current Rating:3.0 Amp
 Voltage Rating:250V AC/DC
 Operating Temperature Range:-40~+105°C

Electrical:

Contact resistance:20m Ohm Max
 Insulator resistance:1000M ohm min.
 Withstanding Voltage:500V AC/Minute

Ordering Information

S25551S2-12Q50-NBB-G
 1 2 3 4 5 6

- 1: — Series No.
- 2: — S2: Straight Type
- 3: — No. of Positions
- 4: — Q: Tin Plated
- 5: — B: B Type
- 6: — B: In Tube

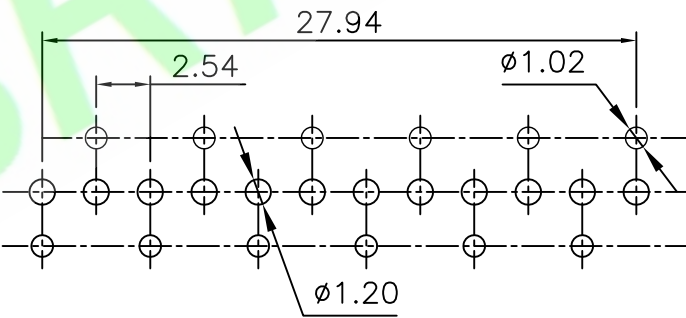
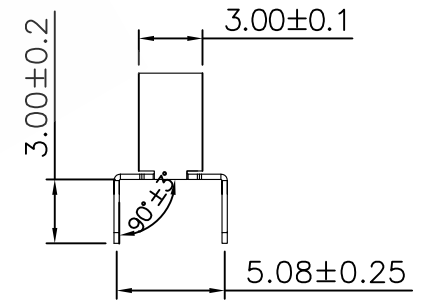
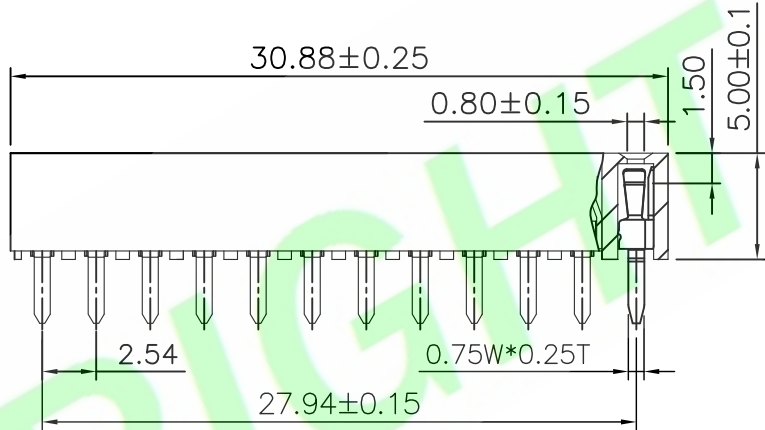
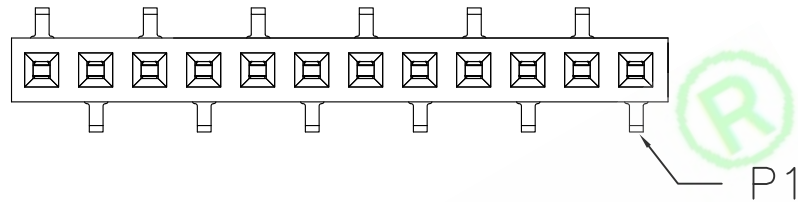

Recommended PCB Layout

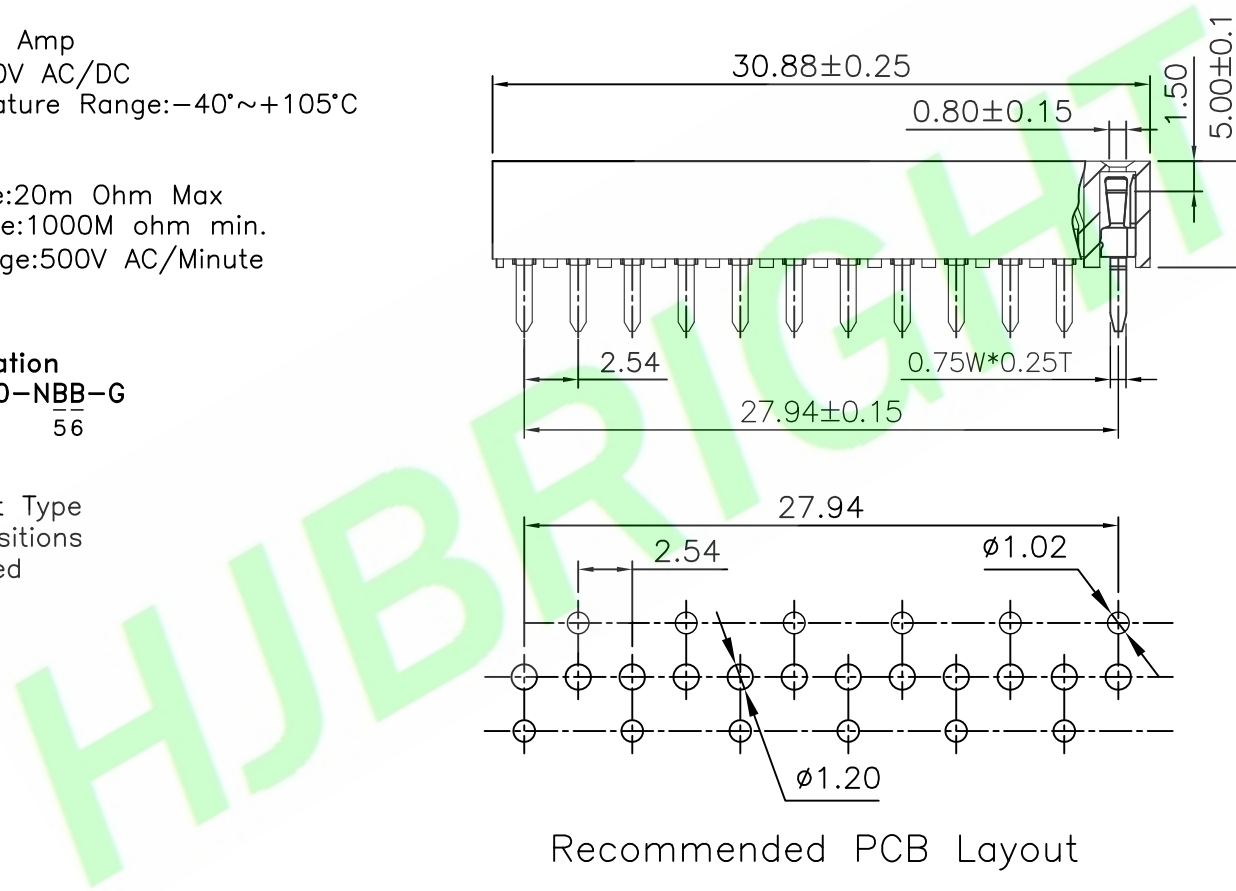

5X				DR.BY.: Kenry	GENERAL TOLERANCE:		PART NO : S25551S2-12Q50-NBB-G		HJBRIGHT 東莞市華晶電子有限公司 BRIGHT-E ELECTRONIC TECHNOLOGY LIMITED
4X				CHKD.: Tony	LINEAR	ANGLES	DWG. NO.:		
3X				APPD.: Billy	X.: ±0.30	X': ±3.0°	TITLE : 2.54mm Pitch PCB		SHEET: 1/1
2X	ORIGINAL	Kenry			X.X: ±0.20	X.X': ±2.0°	Socket Header Straight Type		SCALE: 1:1
1X					X.XX: ±0.15	X.XX':	DATE: 28-Sep-2015		UNIT: mm
REV.	DESCRIPTION	DR.BY	ECN. NO.		X.XXX: ±0.10	X.XXX':			THIRD ANGLE PROJECTION

A4