

Specifications:

Material And Finish:

Insulator:PBT+30% G.F. UL94V-0
 Contact:Copper Alloy
 Plated:See Ordering Information

Rating:

Current Rating:1.0 Amp
 Voltage Rating:100V AC/DC
 Operating Temperature Range:-40~+105°C

Electrical:

Contact resistance:20m Ohm Max
 Insulator resistance:1000M ohm min.
 Withstanding Voltage:1000V AC/Minute

Ordering Information

CS2541-XXX-XX-X

1 2 3 4 5

- 1:— Series No.
- 2:— No. of Positions
- 3:— A:Gold Flash
 Q:Tin Plated
 H:Contact Area:Gold Flash
 Soldertail:Tin 100u”
 K:Contact Area:Gold 5u”
 Soldertail:Tin 100u”

- 4:— 01:W/SR
 02:W/O SR
- 5:— B:In Tube
 C:In Tray

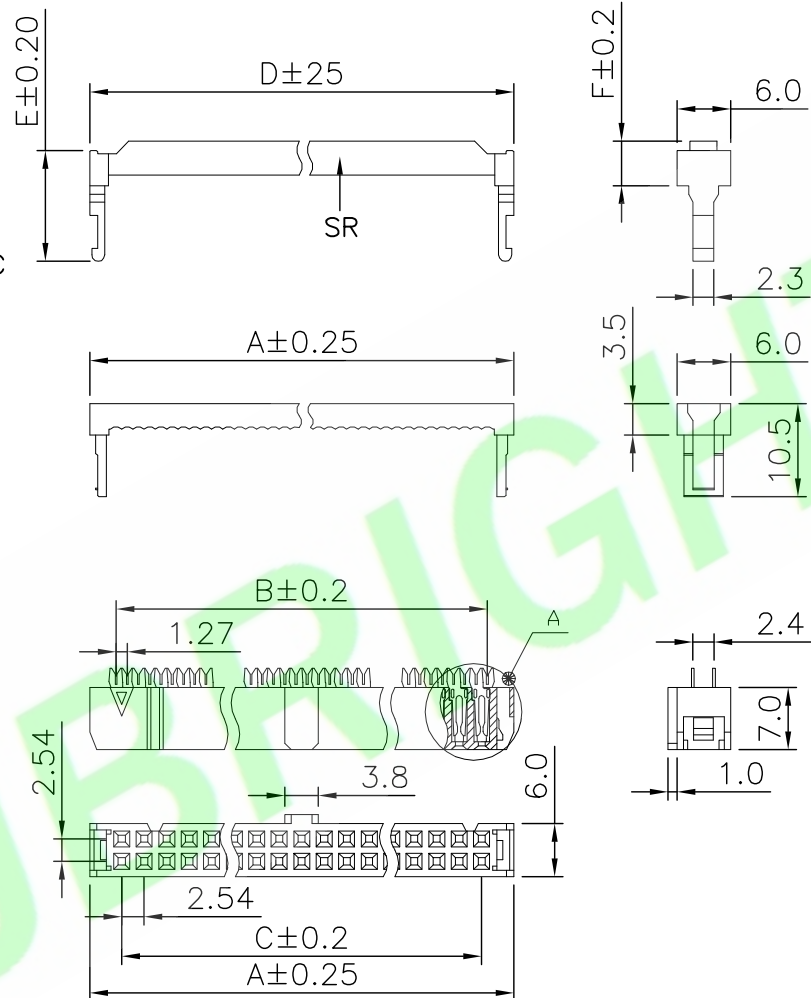

Pos.	Dim. A	Dim. B	Dim. C	Dim. D	Dim. E	Dim. F
6	12.32	6.35	5.08	12.12	13.55	5.00
8	14.86	8.89	7.62	14.66	13.55	5.00
10	17.40	11.43	10.16	17.20	13.55	5.00
12	19.94	13.97	12.70	19.74	13.55	5.00
14	22.48	16.51	15.24	22.28	13.55	5.00
16	25.02	19.05	17.78	24.82	13.55	5.00
18	27.56	21.59	20.32	27.36	13.55	5.00
20	30.10	24.13	22.86	29.90	13.55	5.00
24	35.18	29.21	27.94	34.98	13.55	5.00
26	37.72	31.75	30.48	37.52	13.55	5.00
30	42.80	36.83	35.56	42.80	13.45	4.85
34	47.88	41.91	40.64	47.68	13.55	5.00
36	50.42	44.45	43.18	50.22	13.55	5.00
40	55.50	49.53	48.26	55.30	13.55	5.00
44	60.58	54.61	53.34	60.38	13.55	5.00
50	68.20	62.23	60.96	68.40	13.45	4.85
60	80.90	74.93	73.66	80.70	13.55	5.00
64	85.98	80.01	78.74	85.78	13.55	5.00

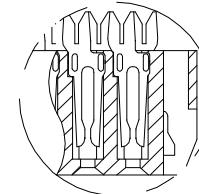

View A(Scale:2:1)

RoHS Compliant

5X				DR.BY.: Samson	GENERAL TOLERANCE:		PART NO : CS2541-XXX-XX-X		HJBRIGHT 東莞市華晶電子有限公司 BRIGHT-E ELECTRONIC TECHNOLOGY LIMITED
4X				CHKD.: Tony	LINEAR	ANGLES	DWG. NO.: RD0904-002		
3X				APPD.: Billy	x.: ± 0.30	x': $\pm 5.0^\circ$	TITLE : 2.54mm Pitch IDC W/SR Type		SHEET: 1/1
2X					x.x: ± 0.20	x.x': $\pm 3.0^\circ$	DATE: 03-Apr-2009		SCALE: 1:1
1X	ORIGINAL	Samson			x.xx: ± 0.15	x.xx': $\pm 2.0^\circ$			UNIT: mm
REV.	DESCRIPTION	DR.BY	ECN. NO.		x.xxx: ± 0.10	x.xxx': $\pm 1.0^\circ$			THIRD ANGLE PROJECTION

A4