

Material And Finish:

1. Brass,Special Hard
2. Plated:Matte Tin Plated
(Tin Plate 150u" Min Thk Copper Or Tin Plate
150u"Min Over 50u" Min The Nickel)
3. Continuous Strip On Reels

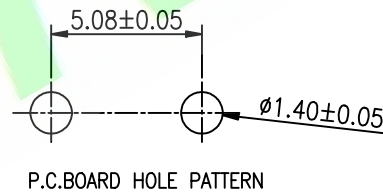
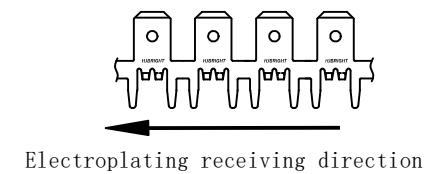
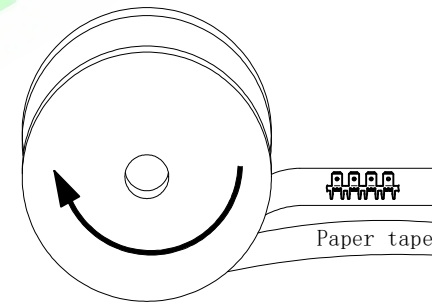
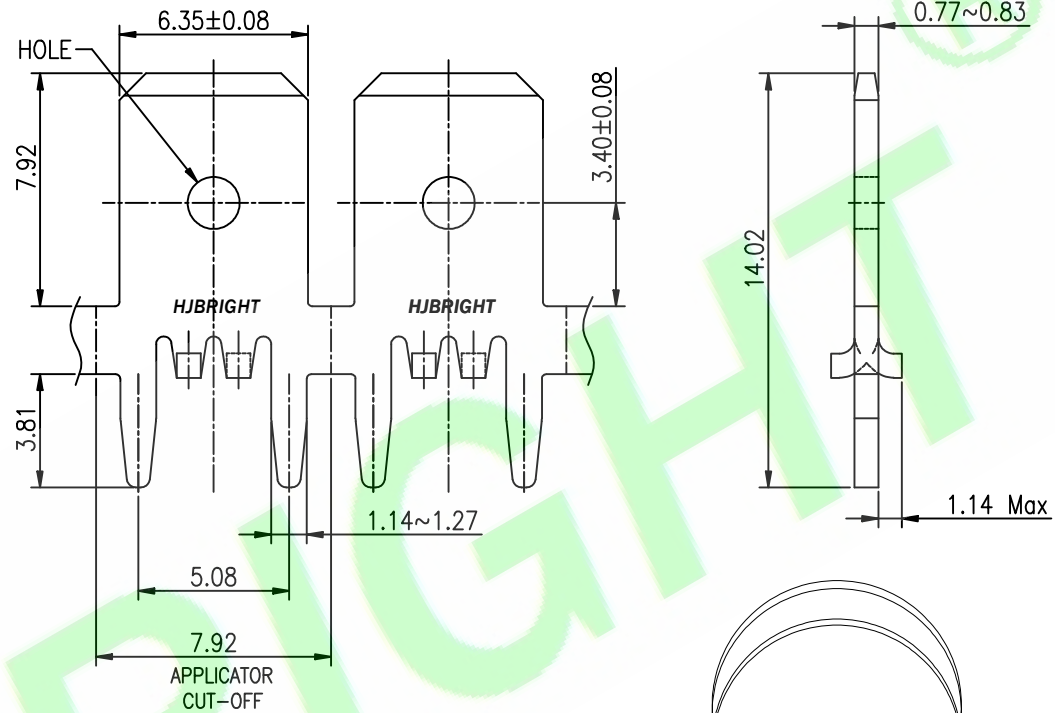

Ordering Information
250BSM-01-TW-R
1 2 3

- 1: — Series No.
- 2: — S:Matte Tin Plated
- 3: — A:In Bag
R:CONTINUOUS STRIP ON REELS

| REV | DESCRIPTION | DR.BY | ECN. NO. |
|-----|--------------------|---------|----------|
| 3X | Update code option | Judyyan | 20250305 |
| 2X | Updating comments | Judyyan | 20240314 |
| 1X | ORIGINAL | Aren | |

| | | |
|-----------------|--------------------|---------------|
| DR.BY.: Aren | GENERAL TOLERANCE: | |
| CHKD.: Aren | LINEAR | ANGLES |
| APPD.: Billy | x.: ±0.30 | x': ±5.0° |
| | x.x: ±0.20 | x.x': ±3.0° |
| | x.xx: ±0.15 | x.xx': ±2.0° |
| | x.xxx: ±0.10 | x.xxx': ±1.0° |

| |
|---|
| PART NO : 250BSM-01-TW-R |
| DWG. NO.: T250080-01-SR |
| TITLE : TAB, FASTON, P.C.BOARD 6.35 [.250] |
| DATE: 02-Sep-2022 |

| | |
|---|----------------------------|
| HJBRIGHT ® 東莞市華晶電子有限公司 BRIGHT-E ELECTRONIC TECHNOLOGY LIMITED | |
| SHEET: 1/1 | THIRD ANGLE PROJECTION |
| SCALE: 1:1 | |
| UNIT: mm | |

A4